

# 3 Tonne Front Tip

## DIMENSIONS & SPECIFICATIONS - MACH2081

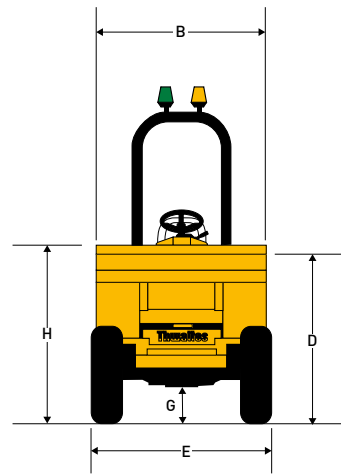
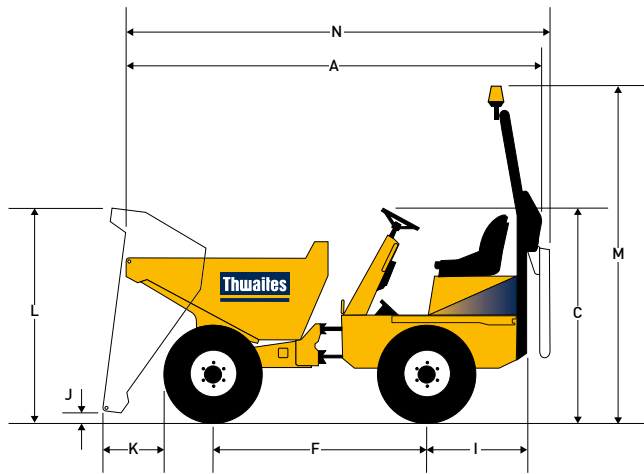

(mm)

A	3785
B	1650
C	1981
D	1381
E	1650
F	1950
G	337
H	1524
I	1042
J	321
K	603
L	2131
M	3108
N	3950

<b>Weight</b>	Unladen	2080 kg
	Shipping	1988 kg

<b>Capacities</b>	Max safe load	3000 kg
	Heaped	1680 litres
	Struck	1350 litres
	Water	1060 litres

### Engine

- › Yanmar 3TNV88-BWWA, water-cooled, 3-cylinder water cooled direct-injection diesel
- › Power 18.1 kW/24.3 bhp at 2000 rpm
- › Torque 107 Nm (78.9 lbf ft)

### Noise Levels

- › Operator's ear 84 LpA / airborne level 101 LwA

### Transmission

- › Hydrostatic with high/low speed range, column mounted directional control lever and inching facility

<b>Speeds</b>	Forward and Reverse	
	Low	0-6.1 km/h ( 3.8 mph)
	High	0-16.1 km/h (10.0 mph)

### Brakes and Axles

- › Totally enclosed multiplate oil-immersed discs mounted on rear axle & auto wear adjustment
- › Hand operated parking brake (SAHR)

### Kinglink Chassis

- › Constructed from folded steel plate, with three point Kinglink giving articulation and oscillation for better stability, traction and safety on site

### Skip

- › Hydraulically operated, 5 mm steel plate all round
- › Skip mouth & sides reinforced with box sections

### Seating & Controls

- › Adjustable suspension seat with high-vis seat belt
- › LED warning lights for all critical functions

### Service Access

- › Lockable engine cover for ground level service points
- › Diesel and hydraulic tanks positioned low permitting access to the filler caps

### Electrics

- › Wiring harness contained within conduits and all electrical components water resistant to IP65/67 standards.

### Steering and Hydraulics

- › Hydraulic power steering
- › Return line filtration for all services
- › Hydraulic test point fitted as standard

<b>Tank Capacities</b>	Fuel	24.5 litres
	Hydraulic	25.0 litres

<b>Turning Circle</b>	9.2m
-----------------------	------

### Standard Equipment

- › LED beacons
- › Towing bracket
- › Reverse alarm

### Optional Equipment

- › Full LED road lighting incl. DRL (Daylight Running Lights)
- › Road mirrors
- › Wheel nut indicator

# Thwaites

Thwaites Ltd, Leamington Spa,  
Warwickshire, CV32 7NQ, England  
Tel +44 (0)1926 422471

[www.thwaitesdumpers.co.uk](http://www.thwaitesdumpers.co.uk)



Images are representative, but specific details or equipment may vary by country. We reserve the right to change any and all specifications without prior notice. 01/2022