

6 Tonne Power Swivel

DIMENSIONS & SPECIFICATIONS - MACH2266

(mm)

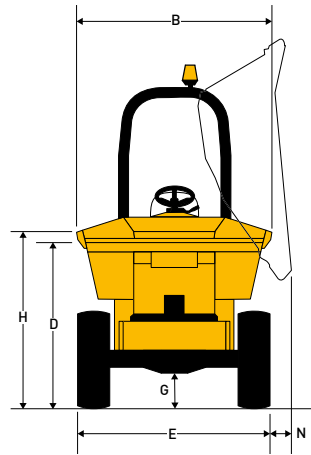
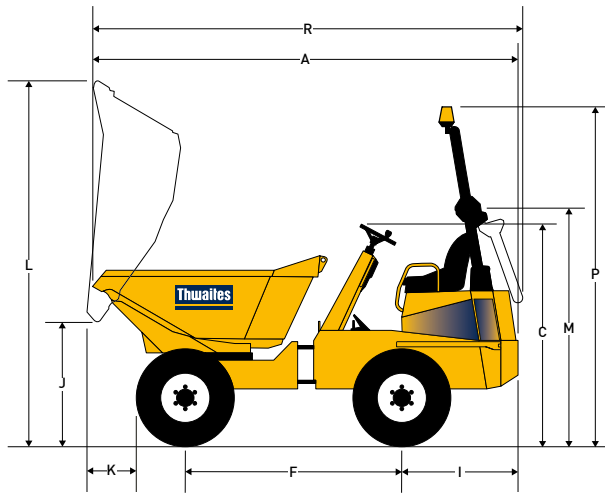

A	4815	N	100
B	2280	P	3430
C	2230	R	5082
D	1670		
E	2240		
F	2480		
G	370		
H	1850		
I	1235		
J	1100		
K	550		
L	3694		
M	2230		

Weight	Unladen	4540 kg
	Shipping	4416 kg

Capacities	Max safe load	6000 kg
	Heaped	3150 litres
	Struck	2550 litres
	Water	1650 litres

Engine

- > Deutz TCD 3.6 L4, water-cooled, 4-cylinder, charged air cooled turbo, fuel injected diesel and after treatment Diesel Particulate filter
- > Power 55.4 kW/ 74 bhp at 2200 rpm
- > Torque 405 Nm (299 lbf ft).

Noise Levels

- > Operator's ear 84 LpA / airborne level 102 LwA

Transmission

- > Torque converter four speed forward and reverse Powershuttle transmission, column mounted speed and directional control lever

Speeds	Forward and Reverse	
	1	5.0 km/h (3.1 mph)
	2	8.0 km/h (5.0 mph)
	3	15.1 km/h (9.3 mph)
	4	27.7 km/h (17.3 mph)

Brakes and Axles

- > Totally enclosed multiplate oil-immersed discs mounted on both axles & auto wear adjustment
- > Hand operated parking brake (SAHR)

Kinglink Chassis

- > Constructed from folded steel plate, with three point Kinglink giving articulation and oscillation for better stability, traction and safety on site

Skip

- > Hydraulically operated, 8 mm steel base plate
- > Skip mouth & sides reinforced with box sections
- > Power Swivel skip enables a 180° rotation

Seating & Controls

- > Adjustable suspension seat with high-vis seat belt
- > Clear operators display unit contains all warning lamps

Service Access

- > Lockable engine cover for ground level service points
- > Rear chassis panel can be hinged back on retainers

Electrics

- > Fuse & relay are housed on a central power distribution board
- > Main harness is fully enclosed in solid conduit and incorporates the engine diagnostic port

Steering and Hydraulics

- > Hydraulic power steering
- > Return line filtration for all services
- > Hydraulic test point fitted as standard

Tank Capacities	Fuel	72 litres
	Hydraulic	50 litres

Turning Circle	12m
-----------------------	-----

Standard Equipment

- > Full LED road lighting incl. DRL (Daylight Running Lights)
- > Camera and dashpanel monitor
- > Reverse alarm
- > LED beacon, fan guard

Optional Equipment

- > Road mirrors
- > Wheel nut indicator
- > GPS speedometer

Thwaites

Thwaites Ltd. Leamington Spa,
Warwickshire, CV32 7NQ. England
Tel +44 (0)1926 422471

www.thwaitesdumpers.co.uk



Images are representative, but specific details or equipment may vary by country. We reserve the right to change any and all specifications without prior notice. 01/2022