

TECHNICAL SPECIFICATIONS
 ARX 16-2 LIGHT TANDEM VIBRATORY ROLLER
 EU Stage V / U.S. EPA Tier 4 final

DIMENSIONS

A	Machine length	2140 mm (84.3 in)
B	Wheelbase	1440 mm (56.7 in)
C	Machine height	2400 mm (94.5 in)
D	Machine height (folded ROPS)	1725 mm (67.9 in)
E	Drum width	900 mm (35.4 in)
F	Working width with offset	948 mm (37.3 in)
G	Machine length (folded ROPS)	2330 mm (91.7 in)
H	Ground clearance	230 mm (9.1 in)
H1	Side clearance	370 mm (14.6 in)
I	Drum diameter	580 mm (22.8 in)
J	Drum shell thickness	13 mm (0.5 in)
K	Machine width (total)	947 mm (37.3 in)

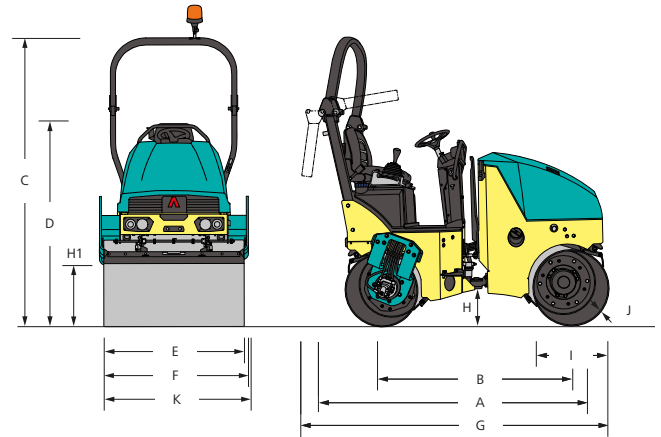

WEIGHT & OPERATING CHARACTERISTICS

Operating weight CECE	1510 kg (3329 lb)
Operating weight max.	1655 kg (3649 lb)
Stat. lin. load of front drum	7.8 kg/cm (17 lb/in)
Stat. lin. load of rear drum	9 kg/cm (19.8 lb/in)
Turning radius inside	2210 mm (87 in)
Steering / Oscillating angle	30/6 ±°
Drum offset	48 mm (1.9 in)

ENGINE

Engine type	Kubota D1105
Emmission class	EU Stage V, U.S. EPA Tier 4 Final
Power output ISO 3046	15.6 kW (21.2 HP)
Cylinder / ltr.	3 cyl / 1123 No./ccm
1. / 2. working speed	2400 / 2600 rpm
Travel speed	8.1 km/h (5 MPH)
Gradeability with / without vibr.	30 % / 35 %

COMPACTION FORCES

Amplitude I	0.5 mm (0.02 in)
Amplitude II	0.5 mm (0.02 in)
Frequency I	60 Hz (3600 VPM)
Frequency II	70 Hz (4200 VPM)
Centrifugal force I	20 kN (4496 lbf)
Centrifugal force II	23 kN (5171 lbf)

MISCELLANEOUS

Battery / Capacity	12/77 V/Ah
Water tank	110 l (29.1 gal)
Hydraulic tank	28.5 l (7.5 gal)
Diesel fuel tank	24 l (6.3 gal)

STANDARD

- Front and rear vibration & drive
- Pressurised pulse interval sprinkler system
- 2 working frequencies
- Control system with emergency stop
- Ammann Vibration Control
- Central lifting point
- Hydraulic test ports
- On-board diagnostics
- Front/rear rubber bumpers
- ATC - Ammann Traction Control
- Battery disconnection switch

OPTIONAL EQUIPMENT

- CE-kit with folding ROPS and working lights
- Road lights
- Infrared thermometer
- Reverse alarm
- Additional working lights (ROPS mounted)
- Warning beacon
- Second drive-lever, left
- Arm rests
- Edge-cutter inc. Multi-function lever
- Bio-degradable hydraulic oil
- Drums In-line
- Customer color
- Weather canopy
- Servicelink